

Draftbooster chimney fan

DRAFTBOOSTER DB7



Description and Application

SCOPE OF APPLICATION

Draftbooster was designed to provide perfect operating conditions for closed wood-burning stoves and fireplace inserts, especially during initial operation, when the chimney draught is ineffective due to the chimney being cold. Draftbooster will also facilitate kindling of firewood and reducing smoke in the room when the door is open. It is available in a matte black and a polished steel version.

FUNCTIONS

Draftbooster is either running full speed, or it is turned off. If, during operation, the draught (in a heated-up chimney) becomes too intense, it is acceptable to turn off the fan. On the fan is an integrated operating switch (Fig. 1-1). This is used in case of the fan or chimney being cleaned.

PRODUCT DESIGN

- Maximum allowable exhaust temperature is 250°C just below the chimney fan
- May be used with wood burning stoves / fireplace inserts with a rated output of 3 to max. 8 [kW]
- All sheet parts are made of stainless steel EN1.4301/AISI304

The unique design and construction are:

- Design protected Nr. 002607085-0001
- Patent pending

APPROVALS

Draftbooster is developed according to requirements in PrEN 16475-2 (Chimney fans)

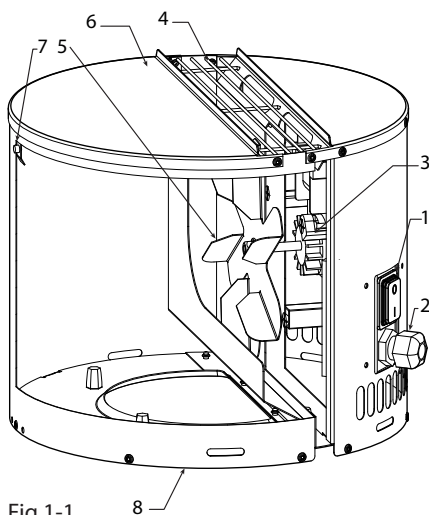
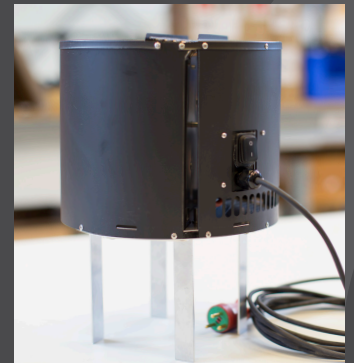

Fig 1-1

- 1 Power
- 2 Cable gland
- 3 Engine
- 4 Net/Return
- 5 Blade
- 6 Cover
- 7 Locking function
- 8 Intake



www.draftbooster.com

Dimensions

| SPECIFICATIONS AND DIMENSIONS | | | |
|-------------------------------|--------|----|------|
| Measurements | A | mm | ø266 |
| | B | mm | 230 |
| | C | mm | ø140 |
| Impedance protected | Ja | | |
| Max. operating temperature | 250 °C | | |
| Max. standstill temperature | 250 °C | | |
| Resistance value [Zeta] | 6,7 ζ | | |

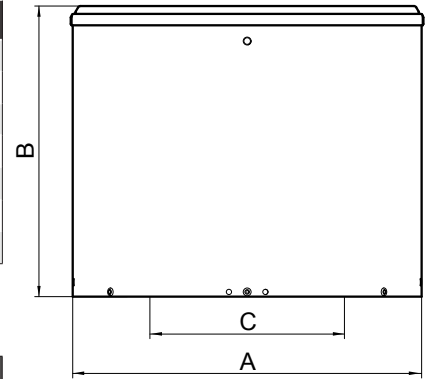

Technical data

| MODEL: DRAFTBOOSTER - DB7EU01 | | | |
|-------------------------------|----------------------|-------|--|
| Vent pipe | Vertical | | |
| Engine type | Shaded pole, class H | | |
| Rev/min | 2,000 | | |
| Voltage | [V AC] | 1x230 | |
| Amperage | [Amp] | 0,27 | |
| Power consumption | [W] | 36 | |
| Weight | [kg] | 3,2 | |

Sound data

| Lp | dB (A)* |
|----------------|---------|
| Sound pressure | 25 |

* Lp = sound pressure level dB (A) at 10 m distance from the fan at halfsperic sound distribution

Sound levels to external surroundings Lp dB (A) measured in accordance with ISO 3744.

Lp (5 m) = Lp (10 m) + 6 dB

Lp (20 m) = Lp (10 m) - 6 dB

Capacity diagrams

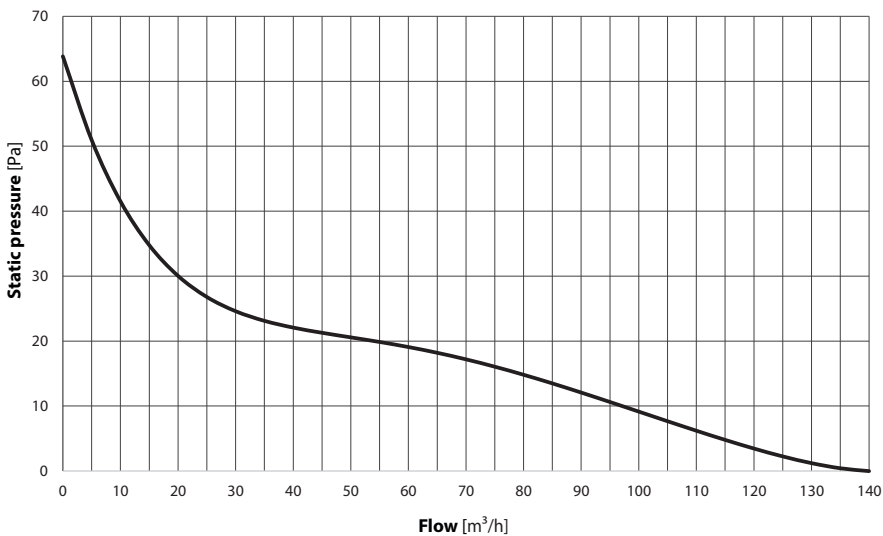

PLEASE NOTE:

The capacity diagrams are measured with a flue gas temperature of 20 °C. The fan's capacity changes with the temperature of the flue gases. The correction of the capacity can be calculated using the following equation:

P_{S_t} = static pressure at a certain temperature (t)

t = temperature measured in °C

$P_{S_{20}}$ = static pressure at 20 °C

$$P_{S_{20}} = P_{S_t} \times \frac{(273 + t)}{293}$$

EXAMPLE:

System demand: 53 m³/h and 13 Pa at 180°C

Fan selection: 53 m³/h and 20 Pa at 20°C

$$P_{S_{20}} = 13 \times \frac{(273 + 180)}{293}$$



www.draftbooster.com